

JAMES STIRLING
Axonometrieën / Axonometric Drawings

1
James Stirling, Sheffield
University, 1953

2
James Stirling en / and
James Gowan, Leicester
University Engineering
Building, 1959-1963

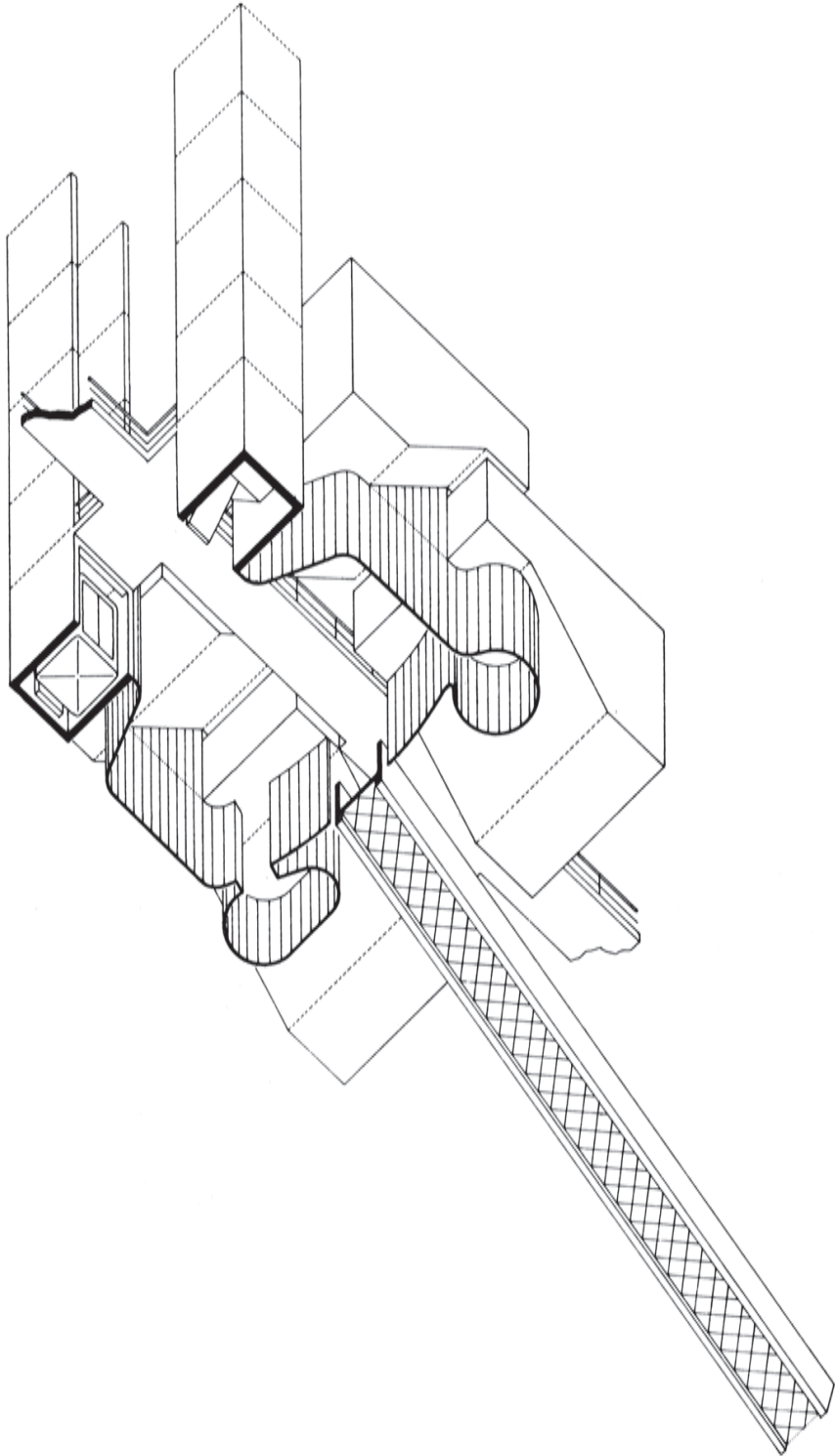

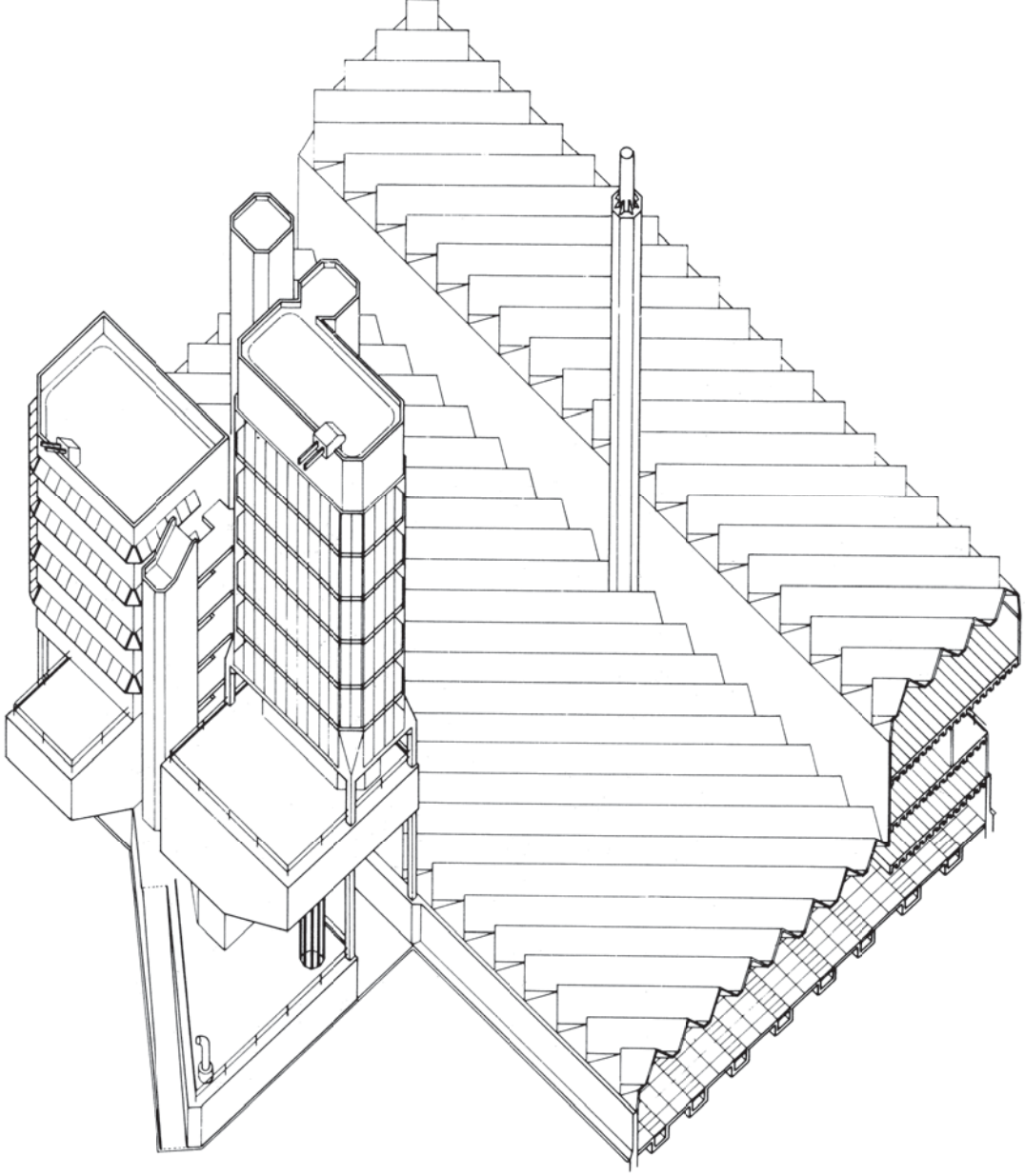

3
James Stirling, Cambridge
University History Faculty
Building, 1964

4
James Stirling, Dorman Long
Headquarters, 1965

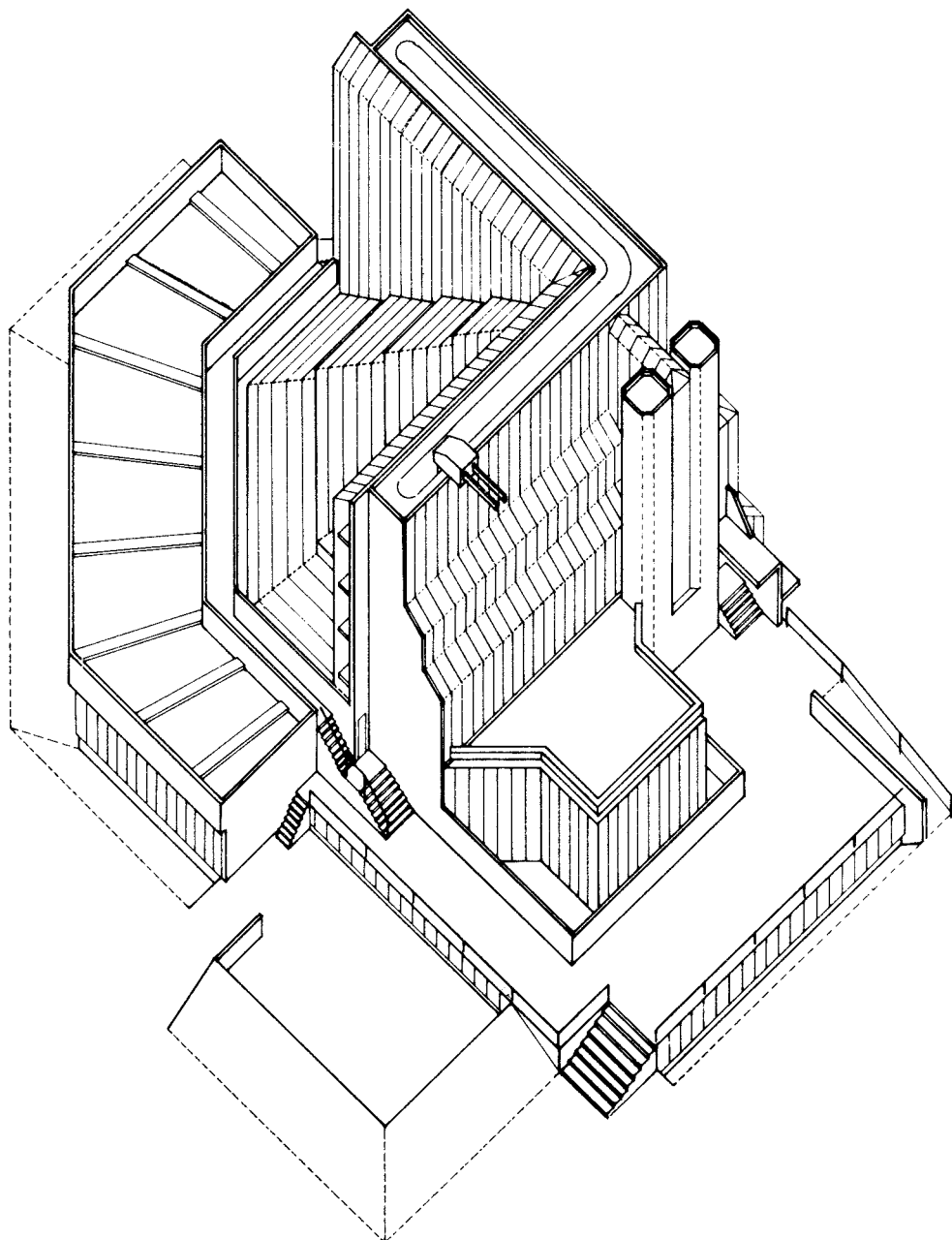

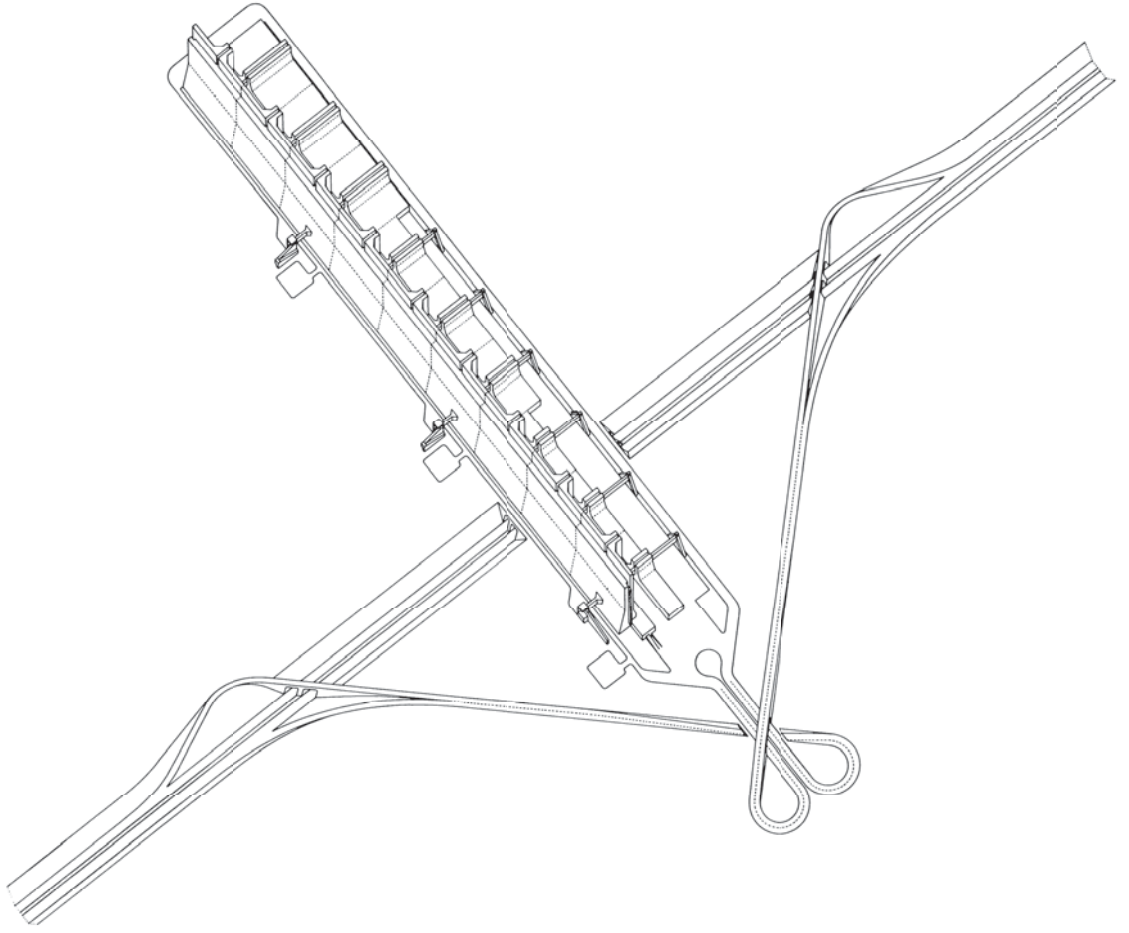

5
James Stirling, The Florey
Building, Queen's College,
Oxford, 1966

6
James Stirling, Siemens AG,
München / Munich, 1969

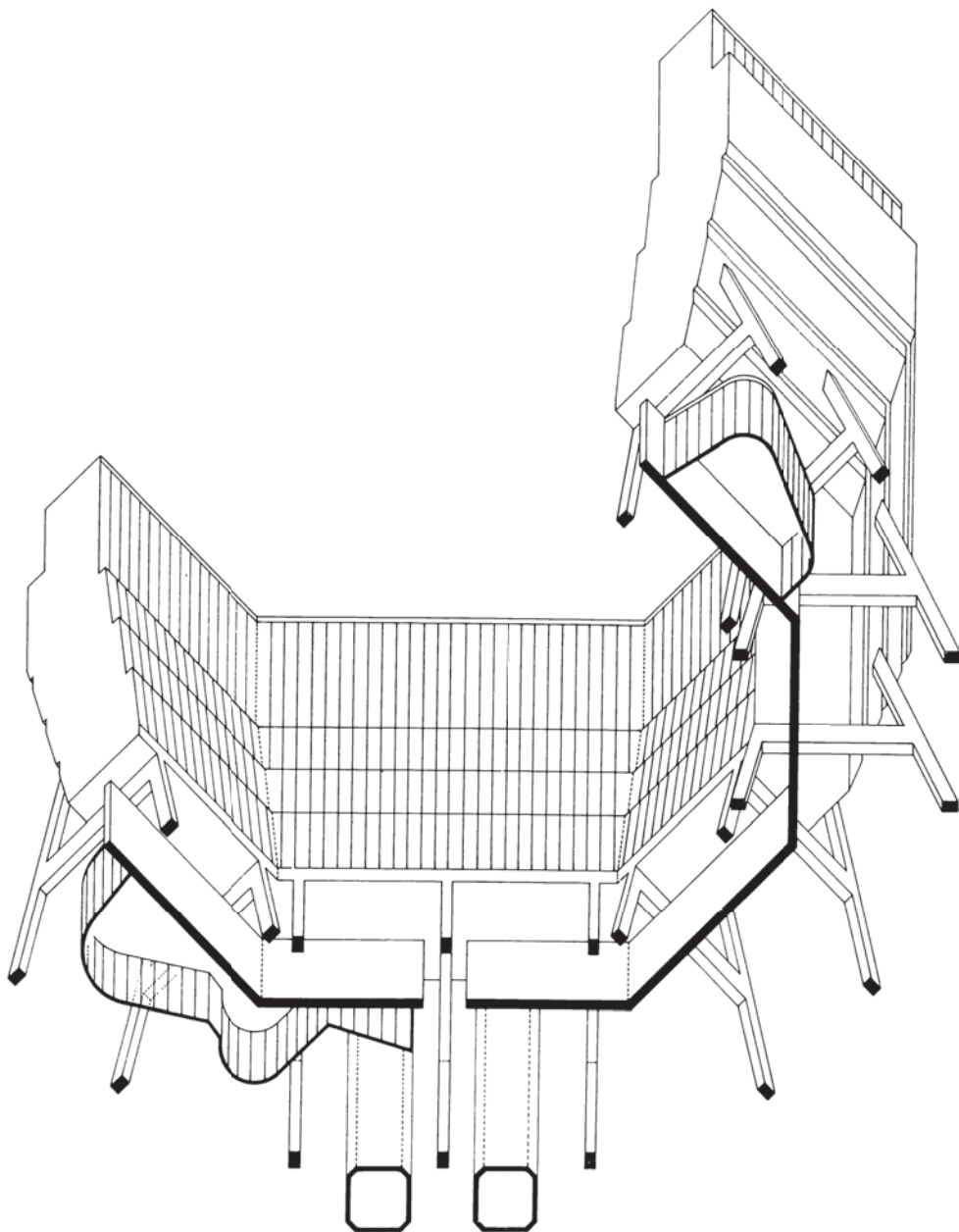

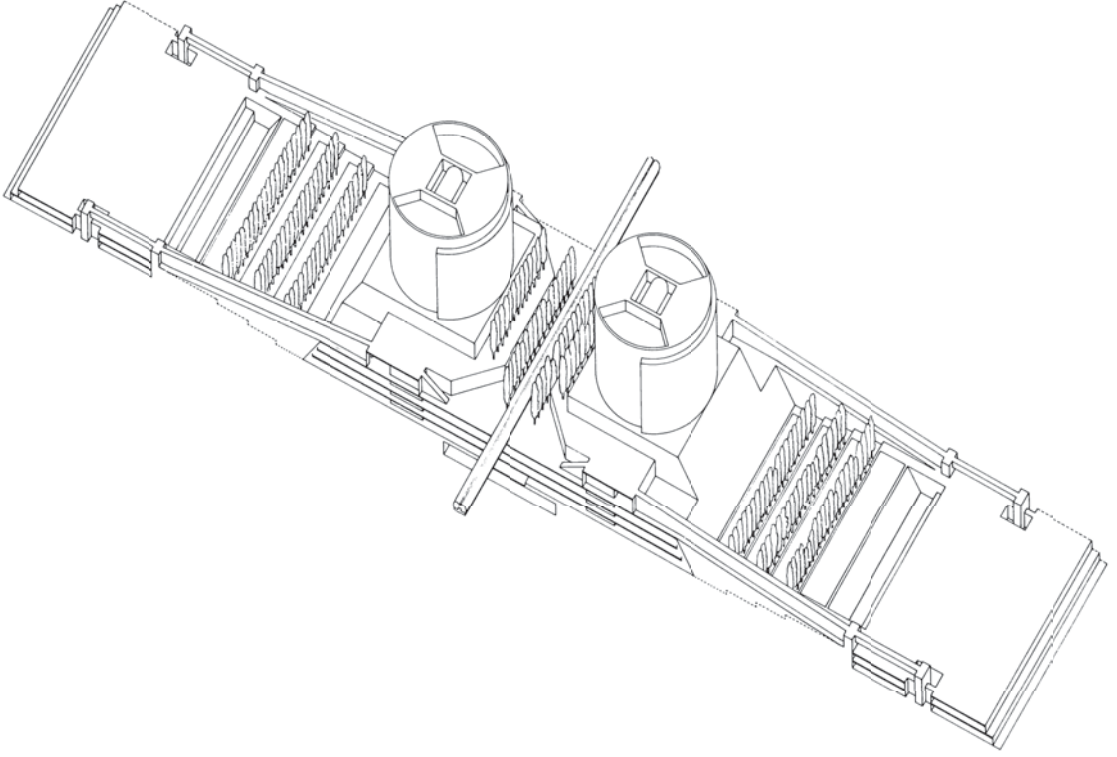

7
James Stirling, Olivetti
Training School, Haslemere,
1969

8
James Stirling, Olivetti
Headquarters, Milton Keynes,
1971

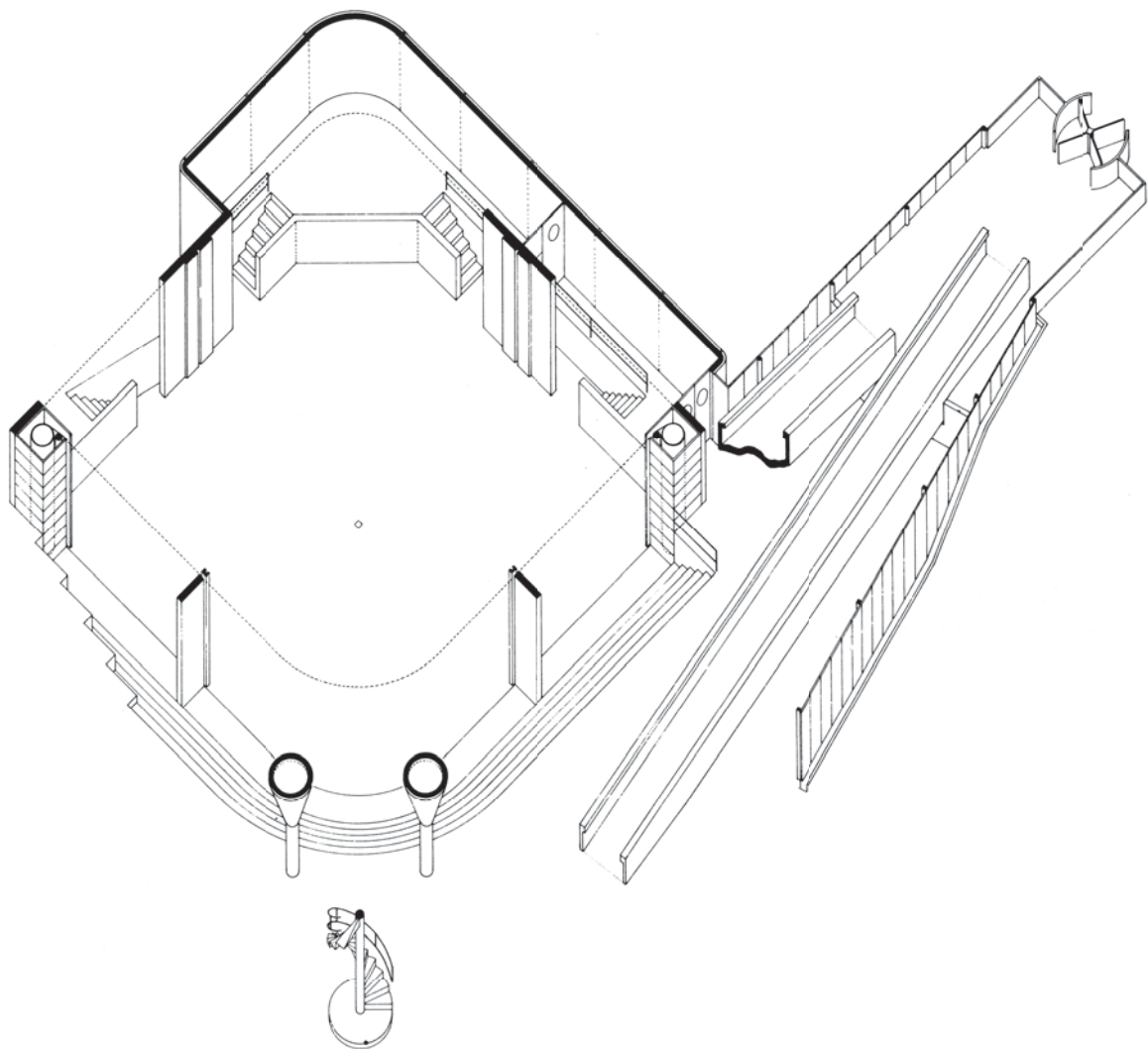

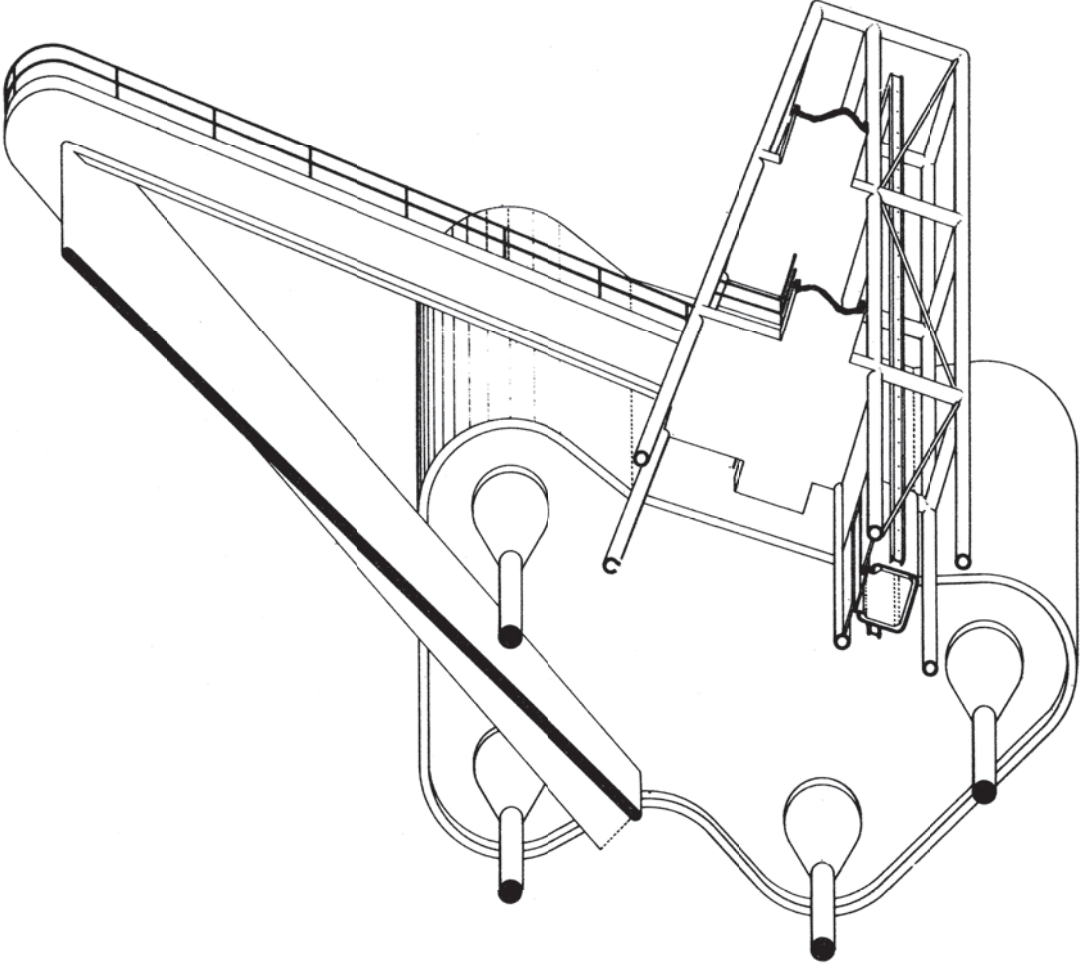

9
**James Stirling, Arts Centre,
St Andrews University, 1971**

10
**James Stirling en / and
Michael Wilford,
Kunstsammlung Nordrhein-
Westfalen, Düsseldorf,
1975**

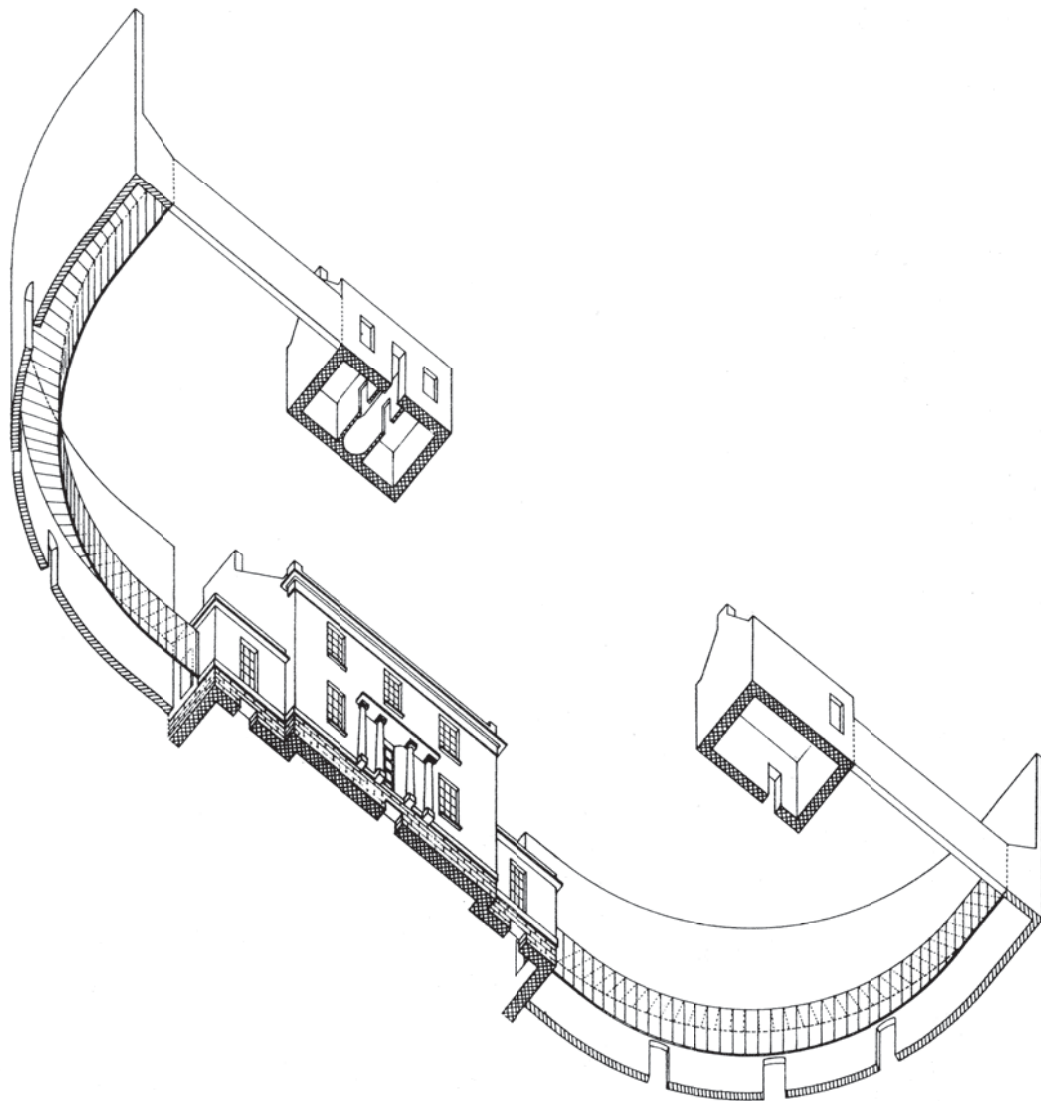

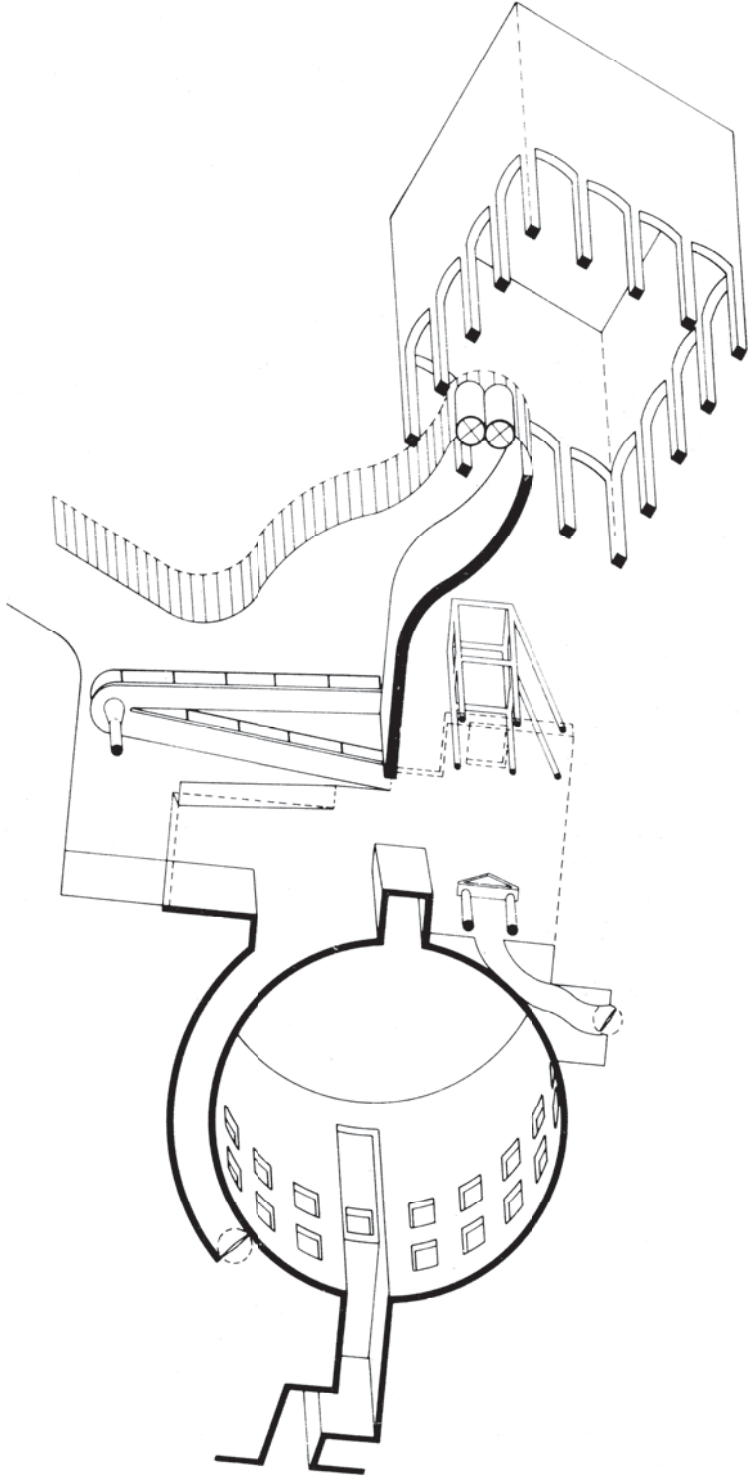

11
James Stirling en / and
Michael Wilford,
Wallraf-Richartz Museum,
Keulen / Cologne, 1975

12
James Stirling en / and
Michael Wilford,
Neue Staatsgalerie,
Stuttgart, 1977

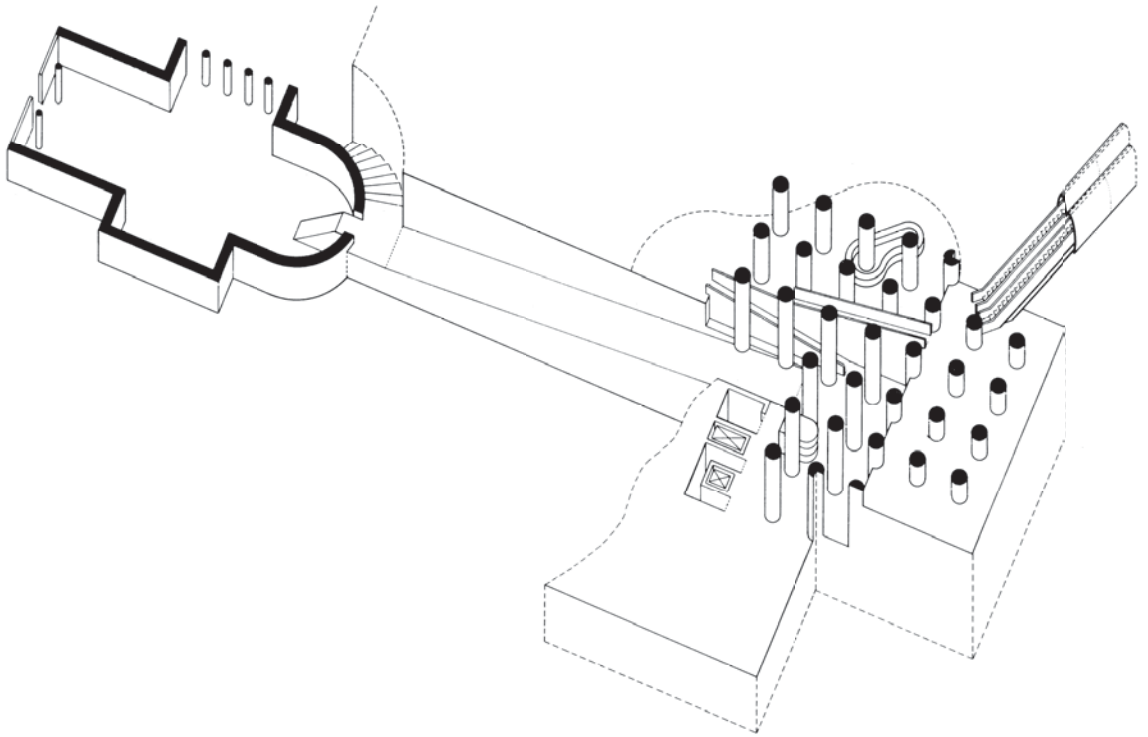

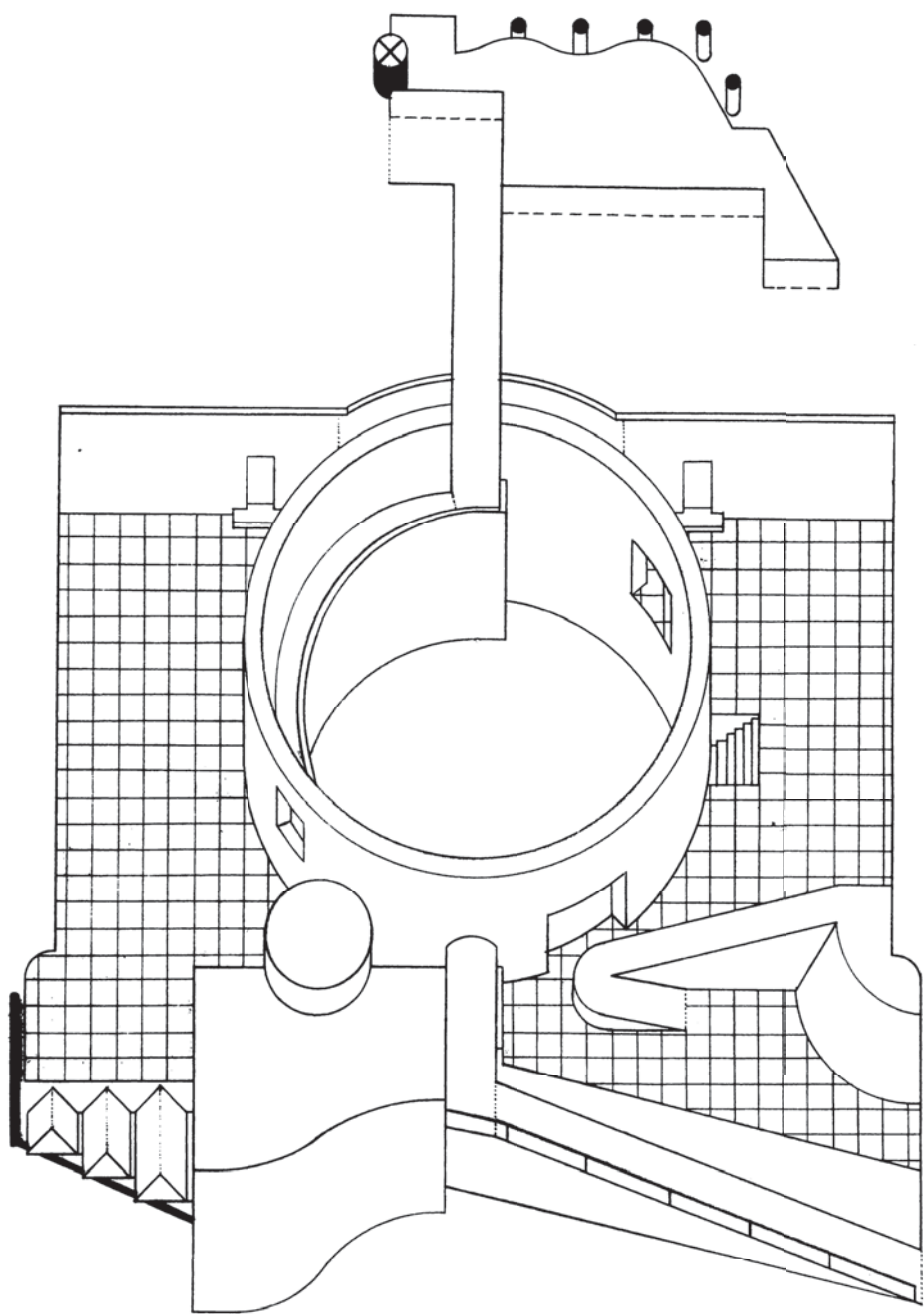

13
James Stirling en / and
Michael Wilford,
Rice University School of
Architecture, 1979

